



Taylor-Wharton
Since 1742

Taylor-Wharton *Liquid Cylinders*

TPED



Innovative. Convenient. Reliable.

Liquid Cylinders

Superior products...outstanding solutions.

Wherever you need them.

Trust the experts for unsurpassed value, quality and service – worldwide. Our extensive product line offers everything you need to transport, store and dispense liquefied gases.

Portable and vacuum-insulated, our vast array of models will fit your needs and store your contents safely and securely every time. Best of all, these products come from Taylor-Wharton, the leader in quality cryogenic liquid cylinders.

Our extensive line-up includes reliable features that ensure excellent performance:

- *Full Circle Shock-Mount Ring*
- *Polished Heavy Duty Outer Body*
- *Innovative Non-Binding Contents Gauge*
- *Reinforced Lateral Head Support*
- *Color-Coded Relief Valves for Different Pressure Settings*
- *5-Year Warranty on Vacuum*

Liquid Withdraw

Low pressure XL™70LP, XL™126LP, XL™186LP, XL™189LP and XL™250LP
Liquid Nitrogen or Liquid Oxygen

Features

- Rugged, easy to maneuver and versatile
- Designed for low pressure filling, storing and dispensing
- Simple, quick liquid withdrawal
- Sizes for every need, from small volume to frequent usage
- Oxygen service and pressure-building capabilities available

(1) Vented N.E.R based on usable liquid capacity.

MODEL NO.		XL™70LP	XL™126LP	XL™186LP	XL™189LP	XL™250LP
Capacity						
Liquid (gross)	(liters)	70	126	186	189	250
Liquid (net)	(liters)	67	120	180	181	240
Performance						
NER(note 2) (N2)	(% per day)	4.2	2.20	1.30	1.40	1.40
NER (O2 - Ar)	(% per day)	2.63	1.38	0.81	0.88	0.88
NER (CO2)	(% per day)	NA	NA	NA	NA	NA
Relief Valve Setting	(bar)	1.5	1.5	1.5	1.5	1.5
Code		TPED	TPED	TPED	TPED	TPED
Rupture Disc Setting	(bar)	12	12	12	12	12
Dimensions						
Tank Diameter	(mm)	508	508	508	660	660
Type of Base		Round	Round	Round	Round	Round
		Caster	Caster	Caster	Caster	Caster
Tank Height	(mm)	1,100	1,370	1,720	1,280	1,470
Tank Empty Weight	(kg)	71	82	115	116	149
Maximum Product Weight (note 3 & 4)						
N2	(kg)	54	97	145	146	194
O2	(kg)	77	137	206	207	274
Ar	(kg)	NA	NA	NA	NA	NA
CO2	(kg)	NA	NA	NA	NA	NA
Gas Withdrawal Rate						
N2	(m3/hr)	NA	NA	NA	NA	NA
O2	(m3/hr)	NA	NA	NA	NA	NA
Ar	(m3/hr)	NA	NA	NA	NA	NA
CO2	(m3/hr)	NA	NA	NA	NA	NA

(1) Specifications subject to change without notice. (2) NER: Normal Evaporation Rate. (3) Weight of product saturated pressure @ 1 bar: N2, O2 and Ar. (4) Weight of product saturated pressure @ 8 bar: CO2



GL-Series (TPED)



Gas and Liquid Withdrawal

Medium pressure
XL™ 180MP and XL™ 193MP
Liquid or Gaseous Nitrogen,
Oxygen, Argon

- Worry-free, over-the-road transport
- Hard working, tough construction
- Automatic pressure-building and economizer circuits
- Low-loss holding capabilities – conserve during low demand periods

(1) Vented N.E.R based on usable liquid capacity.

(2) Container pressure at or above factory pressure/economizer regulator setting.

(3) Regulator has a pressure delta of 20 psig (1.4 bar/138 kPa).

MODEL NO.		XL™ 180MP	XL™ 193MP
Capacity			
Liquid (gross)	(liters)	180	193
Liquid (net)	(liters)	169	181
Performance			
NER(note 2) (N2)	(% per day)	1.9	1.8
NER (O2 - Ar)	(% per day)	1.2	1.1
NER (CO2)	(% per day)	NA	NA
Relief Valve Setting	(bar)	16	16
Code		TPED	TPED
Rupture Disc Setting	(bar)	25	25
Dimensions			
Tank Diameter	(mm)	508	508
Type of Base		Round	Round
		Footring	Footring
Tank Height	(mm)	1,524	1,600
Tank Empty Weight	(kg)	133	139
Maximum Product Weight (note 3 & 4)			
N2	(kg)	136	146
O2	(kg)	193	207
Ar	(kg)	236	253
CO2	(kg)	NA	NA
Gas Withdrawal Rate			
N2	(m3/hr)	9.2	9.2
O2	(m3/hr)	9.2	9.2
Ar	(m3/hr)	9.2	9.2
CO2	(m3/hr)	NA	NA

(1) Specifications subject to change without notice. (2) NER: Normal Evaporation Rate. (3) Weight of product saturated pressure @ 1 bar: N2, O2 and Ar. (4) Weight of product saturated pressure @ 8 bar: CO2

MODEL NO.		XL™ 176HP	XL™ 208HP	XL™ 247HP
Capacity				
Liquid (gross)	(liters)	176	208	247
Liquid (net)	(liters)	165	198	240
Performance				
NER(note 2) (N2)	(% per day)	2.2	1.9	2.8
NER (O2 - Ar)	(% per day)	1.4	1.2	1.7
NER (CO2)	(% per day)	0.75	0.75	1.3
Relief Valve Setting	(bar)	24	24	24
Code		TPED	TPED	TPED
Rupture Disc Setting	(bar)	36	36	36
Dimensions				
Tank Diameter	(mm)	508	508	660
Type of Base		Round	Round	Round
		Footring	Footring	Caster
Tank Height	(mm)	1,524	1,650	1,470
Tank Empty Weight	(kg)	151	164	201
Maximum Product Weight (note 3 & 4)				
N2	(kg)	133	160	194
O2	(kg)	188	226	274
Ar	(kg)	230	276	335
CO2	(kg)	188	226	274
Gas Withdrawal Rate				
N2	(m3/hr)	9.2	9.2	9.2
O2	(m3/hr)	9.2	9.2	9.2
Ar	(m3/hr)	9.2	9.2	9.2
CO2	(m3/hr)	3.9	3.9	3.9

Gas and Liquid Withdrawal

High pressure XL™ 176HP, XL™ 208HP, and XL™ 247HP Liquid or Gaseous Nitrogen, Oxygen, Argon, Carbon Dioxide, Nitrous Oxide

- Ideal for handling a wide variety of gases or liquefied gases
- Automatic dual pressure building/economizer regulator
- Equipped with an internal vaporizer
- State-of-the-art safety features

(1) Vented N.E.R based on usable liquid capacity.

(2) Container pressure at or above factory pressure/economizer regulator setting.

(3) Regulator has a pressure delta of 20 psig (1.4 bar/138 kPa).

Specifications subject to change without notice.

(1) Specifications subject to change without notice. (2) NER: Normal Evaporation Rate. (3) Weight of product saturated pressure @ 1 bar: N2, O2 and Ar. (4) Weight of product saturated pressure @ 8 bar: CO2

Accessories



Transfer Hoses

- Flexible, stainless steel construction in a variety of handy lengths

PART/MODEL NO.			
Nitrogen and Argon LIQUID or VENT Connection			
CGA 295	4 ft. (1.2m)	3/8 in. NPT	1700-9C65
CGA 295	6 ft. (1.8m)	3/8 in. NPT	1700-9C65
Nitrogen and Argon USE Connection			
CGA 580	6 ft. (1.8 m)	3/8 in. NPT	GL50-8C51
Oxygen LIQUID or VENT Connection			
CGA 440	6 ft. (1.8 m)	3/8 in. NPT	GL50-8C53
Oxygen USE Connection			
CGA 540	6 ft. (1.8 m)	3/8 in. NPT	GL50-8C56
Carbon Dioxide LIQUID or Gas USE Connection			
CGA 320	6 ft. (1.8 m)	3/8 in. NPT	HP50-8C51
Carbon Dioxide Gas VENT Connection			
CGA 295	4 ft. (1.2m)	3/8 in. NPT	1700-9C65
CGA 295	6 ft. (1.8m)	3/8 in. NPT	1600-9C65

Specifications subject to change without notice.

Cryogenic Phase Separators

- Minimizes hazardous splashing and vaporization in 3 sizes to accommodate liquid transfer



PART/MODEL NO.	
2 ¼ in. x 1 3/8 in. OD (3/8 in. NPT)	
(70 mm x 35 mm)	1193-8C80
1 ¼ in. x 1 in. OD (3/8 in. NPT)	
(32 mm x 25.4 mm)	1193-8C82
1 ¼ in. x ½ in. OD (1/8 in. NPT)	
(32 mm x 12.7 mm)	1193-8C83

Specifications subject to change without notice.

External Heat Exchanger

- Increases the gaseous delivery rate
- Easy to connect

PART/MODEL NO.	
External Heat Exchanger	VP50-7C10

Specifications subject to change without notice.

Liquid Cylinders Flow Diagram

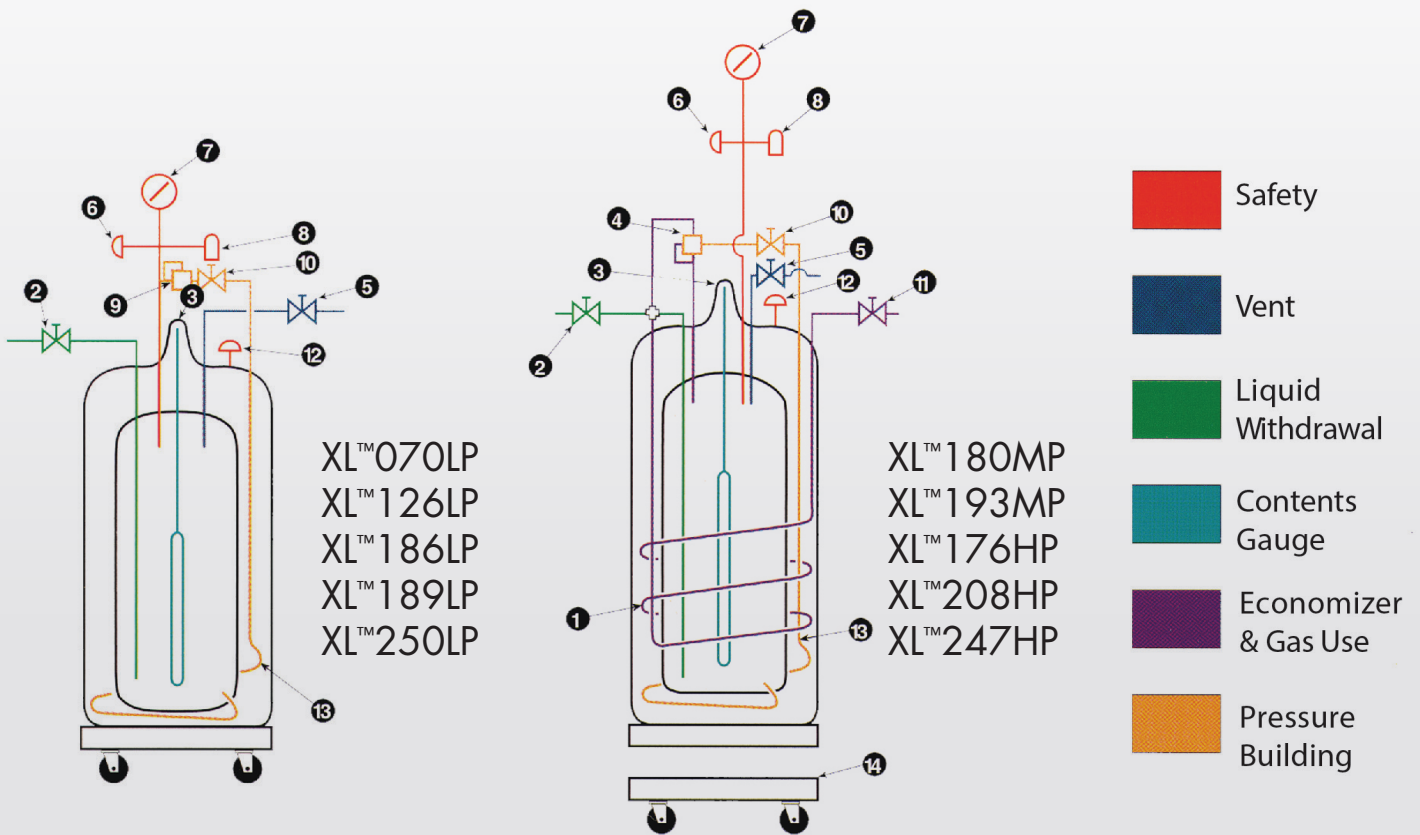

- | | |
|--|---|
| 1. Vaporizer | 9. Pressure Building Regulator |
| 2. Liquid Fill/Withdrawal Valve | 10. Pressure Building Valve |
| 3. Contents Gauge | 11. Gas Withdrawal (USE) Valve |
| 4. Dual Pressure Building/Economizer Regulator | 12. Vacuum Port |
| 5. Vent Valve | 13. Pressure Building Coil |
| 6. Inner Containing Bursting Disc | 14. Square base for GL-65 to GL-70/70HP only, optional five caster base or four caster base with Sure-Grip handle available |
| 7. Pressure Gauge | |
| 8. Pressure Relief Valve | |

Cryogenic Solutions. *Everywhere.*

*World Wide Locations • Multi-Lingual Staff
Customized Solutions • Superior Products
Quality • Innovation • Value*

THE
ORIGINAL
INNOVATORS OF CRYOGENIC
EQUIPMENT



Taylor-Wharton
Since 1742

Email: Europe@twcryo.com

Web: www.twcryo.com