



Priorclave's Smart front-loading autoclaves are intended for industrial, research, and production labs and facilities with greater or more diverse needs. They can adeptly handle standard tasks (e.g., media prep, waste loads, labware) but can also produce drier loads and more reliably handle complex loads that tend to trap air. Ideal for mixed waste loads, biological waste or pathogen-heavy materials, cloth and textile sterilisation, soil and substrate preparation, wrapped instruments, and porous loads. These sterilisers feature fully customisable cycles (with expanded memory), pre-cycle and post-cycle vacuum, integrated cooling and freesteaming, and air intake filtration.

## SPEAK WITH AN AUTOCLAVE EXPERT



+44 (0)20 8316 6620 • [priorclave.co.uk](http://priorclave.co.uk) • [sales@priorclave.co.uk](mailto:sales@priorclave.co.uk)

Our highly trained service technicians provide dedicated pre- and after-sales support including planned maintenance programmes to ensure you get the most from your Priorclave.

## KEY FEATURES

- Quickseal single-action door fitted with thermal and pressure locks to prevent opening at load temperature above 80°C and pressures above 0.2 bar.
- Tactrol® 3 microprocessor control with simple and fully variable setting of process time, temperature with graphic indication of cycle status.
- Automatic timed free-steaming.
- Pre-cycle vacuum in which multiple Vacuum stages are programmed with interspersed heating to achieve steam penetration.
- Pulsed freesteaming to maximise efficiency of Pre-cycle vacuum phase.
- Vacuum Assisted Cooling.
- Low water level sensor.
- Post Cycle Drying for faster load drying.
- Two full width stainless steel load shelves.
- Epoxy coated panels and frame members are treated with an anti-bacterial agent which is effective against all bacteria and fungi including MRSA.
- Pressure vessel carries a 10 year warranty and is insurance approved.
- Service and support direct from manufacturer (or appointed distributor).

## 100L AUTOCLAVE FRONT LOADING

EH100-SMART, SH100-SMART

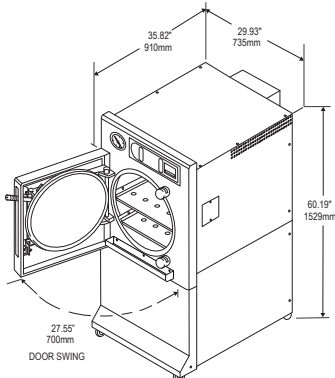

Heat Input	Chamber Volume	Operating Range	Loading Format	Loading Height	Heating Power
Internal Electrical or Direct Steam Source	100 Liters	Up to 138 °C, 2.4 Bar (280 °F 34 psi)	Front Loading	860mm (33.9")	7kW at 30A; 7kW at 15A
Chamber Dimensions diameter x depth		Bottom Shelf Dimensions w x d		Top Shelf Dimensions w x d	
500 x 535mm (19.5" x 21.1")		375 x 535mm (14.76" x 21.06")		485 x 536mm (19.09" x 21.06")	
Outside Dimensions w x d x h	Weight (unloaded)	Minimum Installation	Door Swing		
735 x 910 x 1529mm (29.93" x 35.82" x 60.19")	190Kg (429.9lbs)	Please allow 500mm (19.69") either side and 300mm (11.81") at the back of the Autoclave.	700mm (27.55")		

## 150L AUTOCLAVE FRONT LOADING

EH150-SMART, SH150-SMART

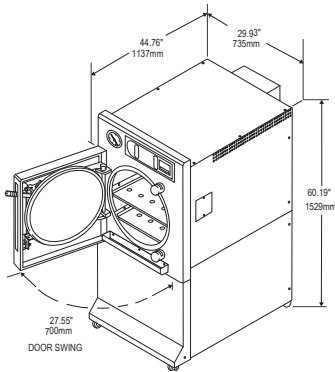

Heat Input	Chamber Volume	Operating Range	Loading Format	Loading Height	Heating Power
Internal Electrical or Direct Steam Source	150 Liters	Up to 138 °C, 2.4 Bar (280 °F 34 psi)	Front Loading	860mm (33.9")	7kW at 30A; 10.5kW at 15A
Chamber Dimensions diameter x depth		Bottom Shelf Dimensions w x d		Top Shelf Dimensions w x d	
500 x 740mm (19.68" x 29.13")		375 x 740mm (14.76" x 29.13")		485 x 740mm (19.09" x 29.13")	
Outside Dimensions w x d x h	Weight (unloaded)	Minimum Installation	Door Swing		
735 x 1137 x 1529mm (29.93" x 44.76" x 60.19")	208Kg (458.6lbs)	Please allow 500mm (19.69") either side and 300mm (11.81") at the back of the Autoclave.	700mm (27.55")		

## 200L AUTOCLAVE FRONT LOADING

EH200-SMART, SH200-SMART

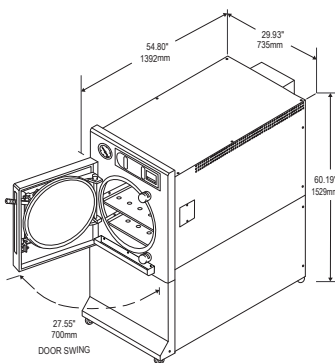

Heat Input	Chamber Volume	Operating Range	Loading Format	Loading Height	Heating Power
Internal Electrical or Direct Steam Source	200 litres	Up to 138 °C, 2.4 Bar (280 °F 34 psi)	Front Loading	860mm (33.9")	7kW at 30A; 10.5kW at 15A
Chamber Dimensions diameter x depth		Bottom Shelf Dimensions w x d		Top Shelf Dimensions w x d	
500 x 1025mm (19.68" x 40.35")		375 x 1025mm (14.76" x 40.35")		485 x 1025mm (19.09" x 40.35")	
Outside Dimensions w x d x h	Weight (unloaded)	Minimum Installation	Door Swing		
735 x 1392 x 1529mm (29.93" x 54.80" x 60.19")	236kg (520.29 lbs)	Please allow 500mm (19.69") either side and 300mm (11.81") at the back of the Autoclave.	700mm (27.55")		

### CONFORMITY & COMPLIANCE

UK Standard	ISO 9001 / CE Marked / BS2646
US Standard	ASME
EU Standard	CE / ISO 9001 / PED 97/23/EC

INT Standard	EMC Compliance
Sustainability	ACT Label Issued
Service	Priorclave Trained Standard